

Departments of the Research School

Plasma Research Laboratory

Introduction

The earliest work on plasma physics in the School started in late 1958, under Oliphant, in the Department of Particle Physics: a small group led by Hilary Morton began a series of experiments on fast, high current gas discharges - to study various forms of magnetic 'pinch' configurations then being explored internationally - as well as on more conventional arc discharges. The possibility of using the homopolar generator (HPG) as a very high power source of discharge current was also considered.

The group was expanded in 1964-5 when Bruce Liley and Colin Vance arrived, and planning for toroidal pinch experiments began, eventually leading to the tokamak apparatus discussed below. The Department changed its name to Engineering Physics about this time.

Following the 1976 School Review, it was decided to combine the Plasma Physics Group with the HPG team to form a new 'Independent Plasma Activity', with the HPG to be used solely as a power supply for plasma physics experiments. (Hitherto the HPG had been used for a variety of projects in the Department of Engineering Physics, including a rail-gun and a high-field magnet.) This 'Activity' became a new department in the School (the Plasma Research Laboratory, PRL) after the arrival of Sydney Hamberger as its Head late in 1977.

Over the years there have been strong links with the Department of Theoretical Physics. Bob Dewar did theoretical work on runaway electrons with Strachan on LT-3 while a Research Fellow in the Department of Theoretical Physics, and subsequently worked on the early theory of the heliac at Princeton University, before returning to the Department of Theoretical Physics in 1982. In 1995, upon Hamberger's retirement, he became Head of the Plasma Research Laboratory, while retaining his membership of the Department of Theoretical Physics. Other members of Theoretical Physics who have contributed much to the Laboratory are Sy and Henry Gardner. Gardner, in particular, wrote his thesis on the stability of the heliac and became a Research Fellow in the laboratory where he has conducted research on equilibrium, stability and transport in the heliac.

LT-3 Tokamak (1964-1978)

In 1964, Bruce Liley, together with Hilary Morton and Colin Vance, began a detailed investigation of plasmas magnetically confined into toroids. In order to find the best magnetic geometry (that is, how tightly the magnetic field lines should best be twisted inside the plasma) they built a small device - named, according to successive

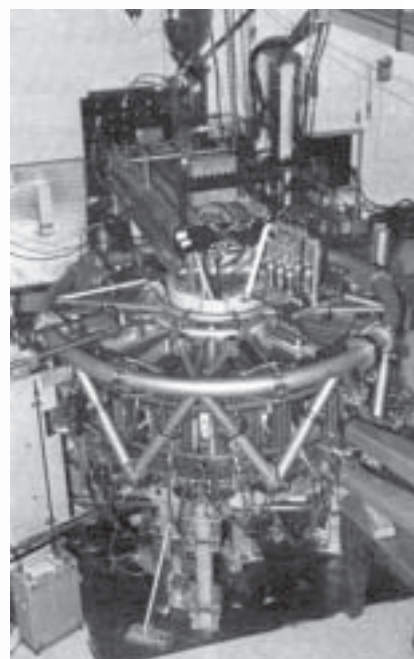

The LT4 Tokamak plasma device that was central to the activities of the laboratory between 1978 and 1985.



Rod Boswell and an early model of the plasma reactor (1990).

versions of its power supply, LT-1, LT-2 and LT-3 - in which the magnetic field geometry could be changed. They found the best results came from a certain class of magnetic configurations that corresponded to those being studied in Moscow in their tokamak experiments. Many of the most important experimental phenomena, such as current disruptions and electron runaway, were in fact first studied systematically in this small device, which was the first (and for five years the only) tokamak outside the USSR. The tokamak has since gone on to be the design most favoured for the first fusion reactors. (People involved included: Bruce Liley, Hilary Morton, Colin Vance, Jim Strachan, Dave Browsers, Mike Bell, Leigh Peterson, Ian Hutchinson, Des Albert, Dick Goldberg and Ray Kimlin.)

The LT-4 Tokamak and the Homopolar Generator (HPG) (1978-1984)

The LT-4 tokamak was constructed in the mid 1970s to capitalise on the knowledge gained from LT-3, by replacing it with a more powerful and sophisticated apparatus that could confine hotter plasma for much longer pulses. Instead of the capacitor banks used hitherto, this required power from the HPG to supply its magnets, a combination which had never previously been attempted. After considerable engineering and operational changes, both to the tokamak and the HPG system, the facility was operated reliably and routinely for several years. The development and installation of advanced diagnostics, plus sensitive feedback on the magnetic field to control the plasma position, enabled more precise measurements to be made of some important plasma phenomena, such as the onset of disruptive instabilities. It also allowed the first experimental use of infra-red imaging of plasma density fluctuations (see later). (Sydney Hamberger, Hilary Morton, Dick Goldberg, Mike Bell, Murray Hollis, Les Sharp, Lew Whitbourn, John How, John Howard, Andrew Cheetham, Hajime Kuwahara and Raffi Nazikian et al.)

Space Plasma and Plasma Processing (1980-)

After Rod Boswell joined PRL in 1980, its interests were extended to plasma phenomena that occur in geophysical space, and apparatus was developed specifically to study these effects in the laboratory. This development included studies of novel ways of producing plasma by launching a special kind of high-frequency wave, known as a 'helicon',

using radio-frequency transmitters. It also included developing new plasma simulation codes to help understand and predict the complex non-linear plasma behaviours which were studied experimentally. It soon became clear that these methods could be readily adapted to the efficient production and understanding of large volumes of chemically reactive plasma, such as used industrially (e.g. to etch semiconductor wafers), and significant funding from both private and government sources was obtained to exploit this opportunity. The ability of the technique to operate over a wide range of plasma composition and conditions resulted in etching performance superior to that in general use, so that helicon reactors are now in operation (under licence) in several overseas countries. Further development of the concept showed that high-quality material, such as optical quality silica, could be deposited, and this led to other successful development; for example, of special planar optical waveguide devices. (Rod Boswell, Andrew Perry, Rob Porteous,

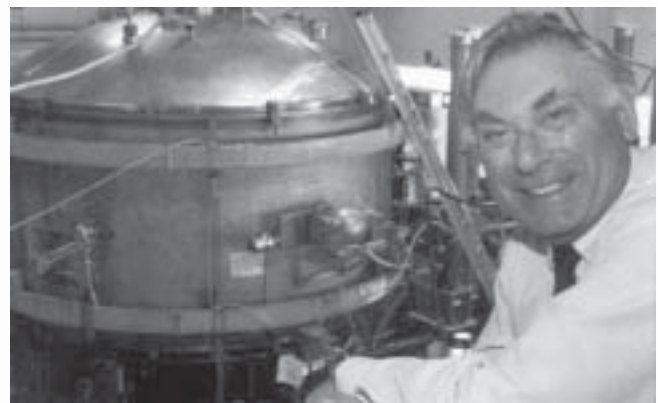

Sydney Hamberger and the H-1 plasma device.

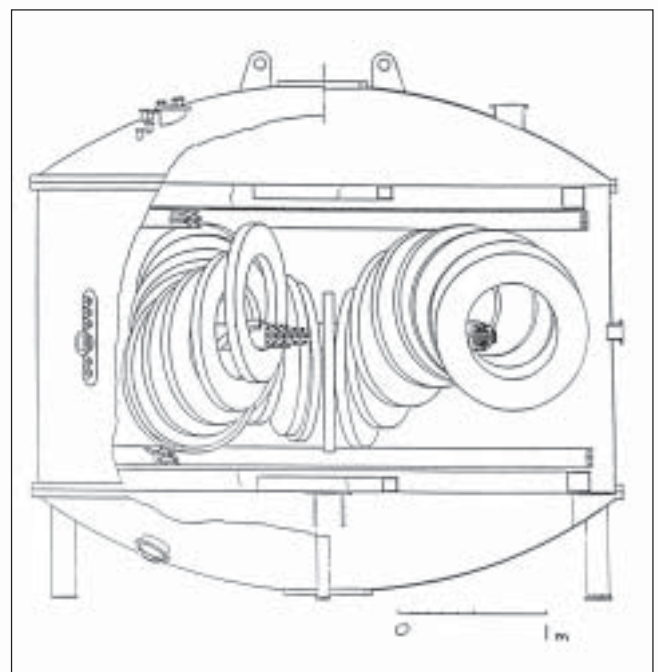

A section view of the H-1 device, showing the helical configuration of the array of field coils.

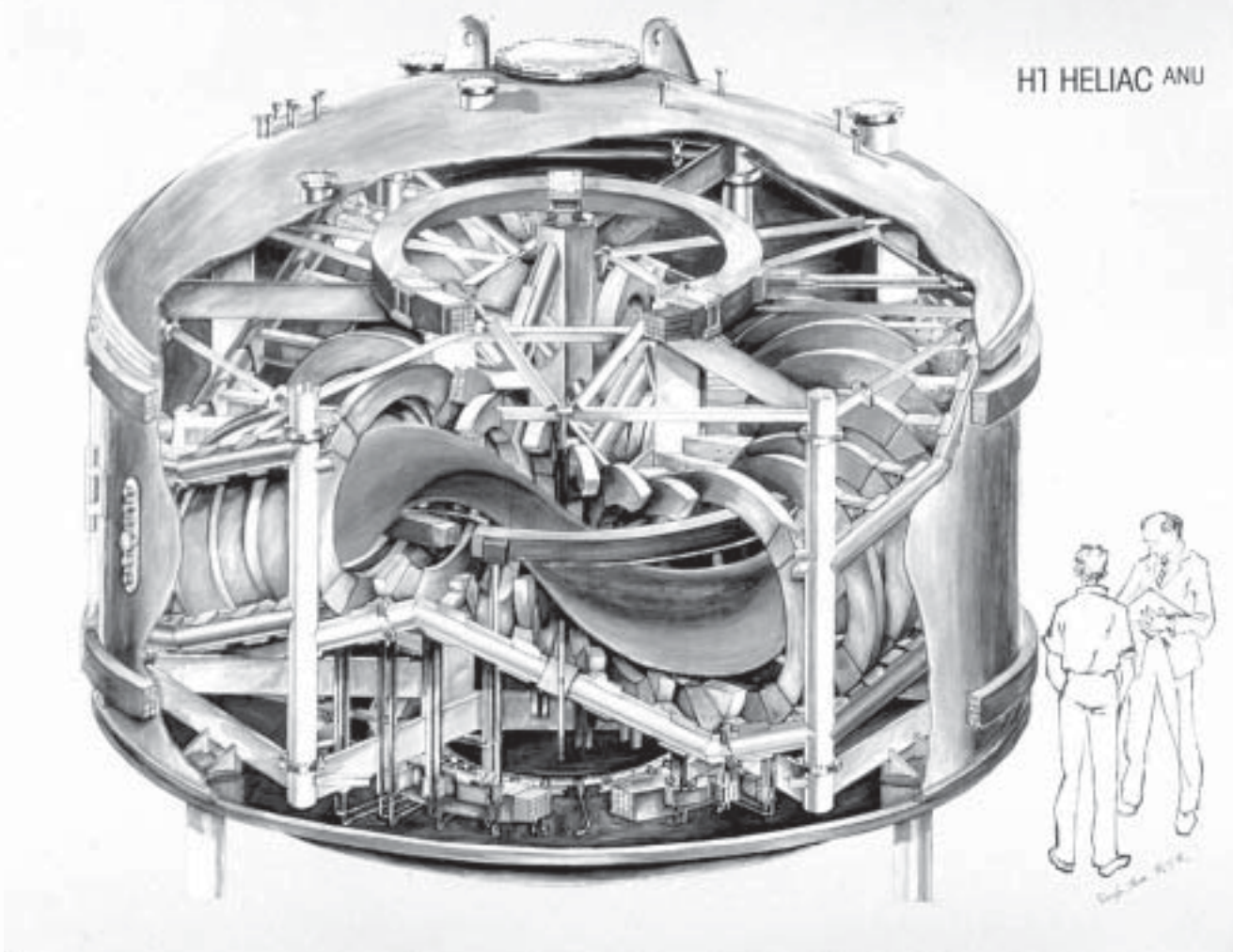

Christine Charles, Antoine Durandet, Arnstein Prytz, Ian Morey, Peiyvan Zhu, Chunshi Cui, David Vender, Helen Smith, Darryn Schneider and many visitors.)

The Heliac project (1984-)

In contrast to the mid 1960s, when tokamaks existed only in the USSR and in Canberra, by the early 1980s there were several hundred around the world and the competition was such that it was very difficult for a small group to make a visible contribution. Equally, overseas interest in an alternative concept, the stellarator, in which several of the senior members of PRL had expertise, was growing rapidly, so that it became opportune to change direction by investigating a novel type of stellarator, known as the heliac. This was based on an idea which was mainly developed at Princeton and that offered a great opportunity for ANU to be the first in the world to explore some new magnetic configurations which had great potential for fusion reactors. To prove the feasibility of the heliac concept, a small apparatus called SHEILA was built and successfully and productively operated from

1984, when the HPG, together with its dependent experimental apparatus, the LT-4 tokamak, were closed down, until 1994. (Sydney Hamberger, Jack Blamey, Les Sharp, Boyd Blackwell, Tou Tek Yong, Garrard Conway, Xuehua Shi, Peter Loewenhardt, Beichao Zhang and Roy Tumlos.)

The great success of SHEILA encouraged PRL to design and build a much larger version, called H-1, which would operate without the HPG (directly from the mains power supply) and on which the department's high temperature plasma research could be based for the foreseeable future. Apart from the specialised fabrication of its large vacuum vessel, all the very demanding construction work was performed in-house, by the combined efforts of the PRL technical staff and the School's Mechanical Workshop, and provides an exemplar of the skills and versatility existing in the School. The apparatus, which was built for a small fraction of the cost of a roughly comparable heliac being built in Europe, produced plasma inside confining magnetic field configurations of unprecedented accuracy.

Overseas interest in this project led to Australia

being invited (in 1988) to sign the International Energy Agency Implementing Agreement on Stellarators (now with the European Union, Japan, Russia, Ukraine, and USA) which coordinates international collaboration in this area. More recently, a bilateral exchange agreement was signed with Japan's National Institute for Fusion Science. Together, these agreements have facilitated loans of very valuable equipment (such as high power millimeter wave generators) needed to extend the capabilities of H-1.

In 1995, the Australian Government declared H-1 a National Facility, with a substantial grant (\$8.7M) to upgrade its power supplies to international standards. The heliac now acts as a national focus for high-temperature plasma physics for the whole Australian academic community, under the umbrella of the Australian Fusion Research Group. (Hamberger, Sharp, Blackwell, Barry Shenton, John Howard, Gerard Borg, Misha Shats, technical staff and students.)

Advanced Plasma Diagnostics

Much effort has been devoted to developing highly specialised apparatus and novel methods for making non-perturbing measurements on hot plasma, many based on infrared and far-infrared lasers. For example, the group has developed and built several very sophisticated laser-based systems to study how the plasma is distributed internally and to image its

interior fluctuations. (John Howard, Les Sharp, Hugh Barkley, Raffi Nazikian and George Warr.)

Outside Support

Since its inception, the Laboratory has benefited from financial and other support from sources outside the university. For example, the fusion-energy related (magnetically-confined) plasma research was initially assisted substantially by the Australian Atomic Energy Commission and through the National Energy Research and Development scheme. However, the change in government policy after the 1983 federal election, which favoured short-term applied projects over long-term basic or strategic research such as fusion power, resulted in a major reduction in this support. The 1995 Major National Facility award to the heliac project represented the first significant government support for this activity since the mid 1980s.

On the other hand, the plasma processing work received a significant boost in 1985 with a one-million dollar grant from a new high-tech company, ICOM Ltd. Although this collapsed in 1987 (along with the stock-market), the impetus enabled the group to access other sources of funds. Since then, the work has benefited from a series of government awards (for example, from DITAC and the IR&D Board) as well as from industrial sources, both here and overseas, and through many national and international collaborations.

Sydney Hamberger

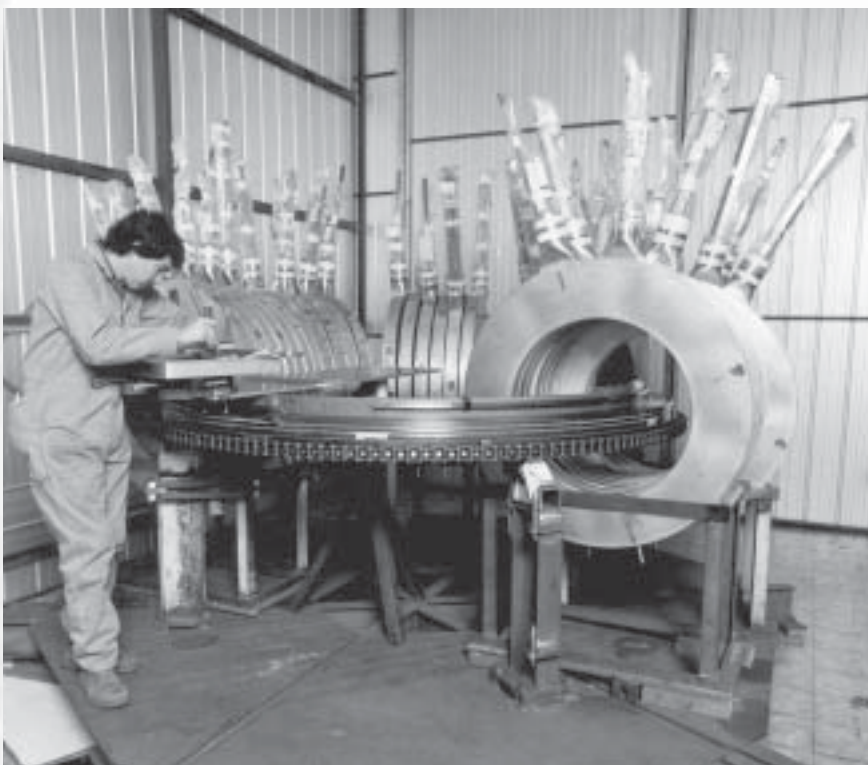

The Heliac during construction.